

WilsonPro A1000

Cellular Signal Booster

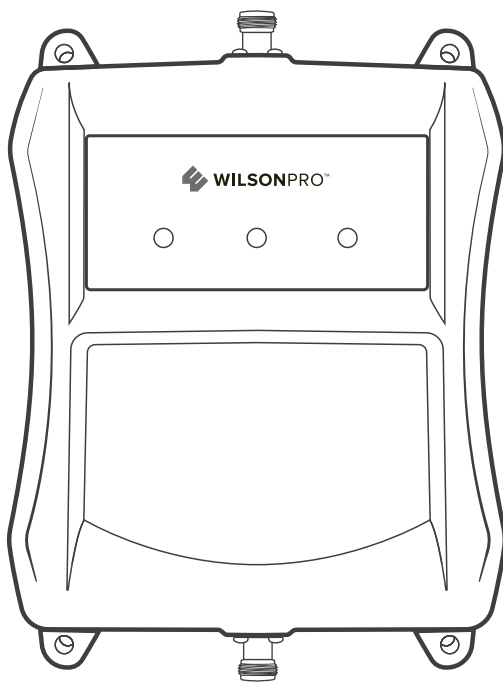

User Manual

NEED HELP?



BoltonTechnicalAfrica.com  +27796793305

Index

Package Contents	1
STEP 1: Preparation	2
STEP 2: Find The dBm Reading On Your Phone	3
STEP 3: Measure Signal Strength For Inside Antenna	4
STEP 4: Measure Signal Strength For Outside Antenna	5
STEP 5: Temporarily Mount The Outside Antenna	6
STEP 6: Connect The System	7
STEP 7: Compare Results	8
STEP 8: Permanently Mount The Outside Antenna	9
STEP 9: Permanently Mount The Inside Antenna	11
STEP 10: Route & Secure The Cable	12
Test System: Lights	13
Specifications	15
Safety Guidelines	16
Warranty	18

Package Contents

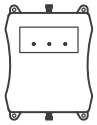

WilsonPro
A1000

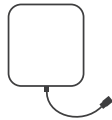

Inside
Antenna

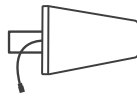

Outside
Antenna

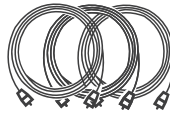

3 Coax Cables
(1m, 10m, 15m)

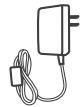

Power
Supply

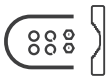

2x Pole Mount
Bracket



Wall Mount
Bracket



Lightning
Surge
Protector



This device may be operated **ONLY** in a fixed location for in-building use. The signal booster unit is designed for use in an indoor, temperature controlled environment (38 degrees Celsius)

We recommend plugging in the power supply into a power strip to protect against power surges and installing a lightning surge protector that is earthed.

Step 1: Preparation

You Will Need (tools not included)

Make sure the following materials are prepared and ready for your installation.



2 to 3 hours



2 people (a person to help with antenna calibration)



- Ladder
- Phillips-head screwdriver
- 10mm open-end wrench or adjustable wrench
- Drill (*if routing cable through wall*)
- Mounting Option A**: 25cm diameter pole (#BT512631) or an existing pole
- Recommended:** Power Strip with surge protection

NOTE: These instructions will walk you through a “soft” install process to find the optimal locations for the Inside and Outside Antennas, then through the process of the permanent installation.

Step 2: Find The dBm Reading On Your Phone

Visit: <https://www.BoltonTechnicalAfrica.com/>

iPhone® iOS 9 - 10.3.3

Put your iPhone into field test mode. To do this dial *3001#12345#* then press call.

- 1 Hold down power button until you see 'Slide to Power Off'.
- 2 Then release the power button.
- 3 Hold the Home button until your main screen appears.

If you want to check 3G/1x but your iPhone is picking up 4G/LTE signal, go to Settings>Cellular>Cellular Data Options>Enable LTE>Select Off.

After your system is set up, you can go back to the dots signal by once again dialing *3001#12345#* then pressing call. When the menu comes back up, tap "phone" in the top left corner of your phone.

iPhone® iOS 11 - current

iOS 11 no longer displays the decibel (dBm) reading in 'Field Test Mode'. Tip: Using the bar indicator on your cell phone can assist you in finding the strongest signal direction as well as placing calls in different locations. **For changes/updates on this issue, periodically go to:**
www.BoltonTechnicalAfrica.com

iPhone is a registered trademark of Apple Inc. Android is a trademark of Google Inc.

Android™

Settings > About Phone > Status or Network > Signal Strength or Network Type and Strength (exact options/wording depends on phone model).

All Other Phones & Alternate Methods

iPhone



- **OpenSignal** is a free app that allows you to run a test of your iPhone's true speed
- **Speedtest** by Ookla is another free app

Android users: do a signal strength test and network speed test.

- **Network Cell Info Lite**, available for free on the Google Play store, provides nearly real-time monitoring of cellular and WiFi signals

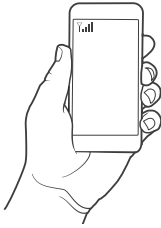
Step 3: Measure Signal Strength For Inside Antenna Placement



Turn off your cell phone's  WiFi to ensure you are checking the cellular connection. The dBm reading will be refreshed every 30-60 seconds. **Want faster results? Once you have a reading, turn on  airplane mode.** Wait 15 seconds. Turn off airplane mode. The signal strength reading is refreshed.

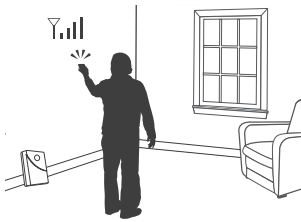

Walk around your home/office taking signal strength readings until you find the area that has the weakest reception, or number farthest away from zero. For example -100 is a weaker signal than -80.





Users on iOS 11 and above will need to use an alternative method using the bar indicator on your cell phone and/or placing calls in different locations.

Weakest Signal Number: _____

Weakest Signal Location: _____

Place your Inside Antenna in this poor signal area. For best results, keep the Inside Antenna more than 45cm away from the booster.

Having an accurate measurement of signal strength in decibels (dBm) is crucial when installing your system. Decibels accurately measure the signal strength you are receiving. Test both 3G and 4G signal for best results by turning the LTE off in the carrier settings of your device.

SIGNAL STRENGTH	EXCELLENT	GOOD	FAIR	POOR	DEAD ZONE
					
3G/1x (typically voice)	-70dBm	-71 to -85dBm	-86 to -100dBm	-101 to -109dBm	-110dBm
4G/LTE (typically data)	-90dBm	-91 to -105dBm	-106 to -110dBm	-111 to -119dBm	-120dBm

Step 4: Measure Signal Strength For Outside Antenna Placement

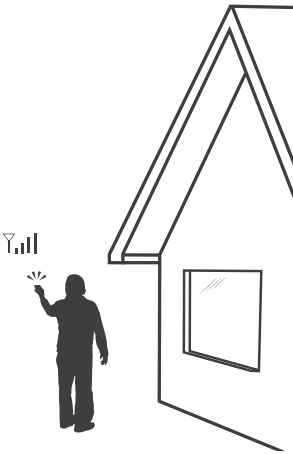

This is the most critical step of the installation process because it will determine the overall performance of the booster system. Using the same method as Step 3, **find the place with the strongest signal (number closest to zero) on the outside of your home.**

Users on iOS 11 and above will need to use an alternative method using the bar indicator on your cell phone and/or placing calls in different locations.

The further apart the Inside Antenna is located from the Outside Antenna, the better. To determine the best location for your Outside Antenna, note the dBm reading in a variety of locations.

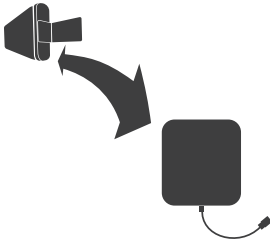

Note: The Outside Antenna must be at least **6 meters vertical or 15 meters horizontal** from the Inside Antenna for best performance. Make sure the Inside Antenna and Outside Antennas are facing away from each other.

Step 5: Temporarily Mount The Outside Antenna

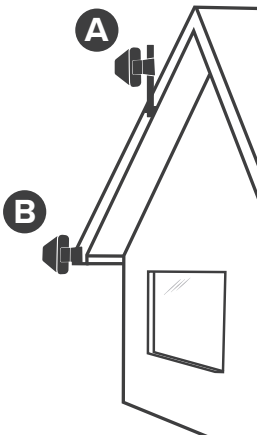

Use one of the two options to mount the Outside Antenna on the side of the house with the strongest signal.

Note: Using an app like 'Open Signal' will help you point the Outside Antenna in the direction of the nearest cell phone tower.

A Option (Best)

B Option (Good)

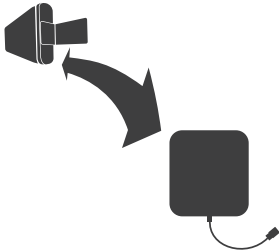

Note: The Outside Antenna must be at least **6 meters vertical or 15 meters horizontal** from the Inside Antenna for best performance. Make sure the Inside Antenna and Outside Antennas are facing away from each other.

Step 6: Connect The System

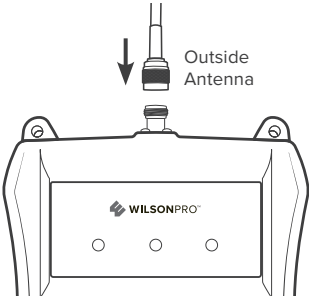

1

Connect the supplied **Coax Cable** to end of booster labeled **Outside Antenna**.

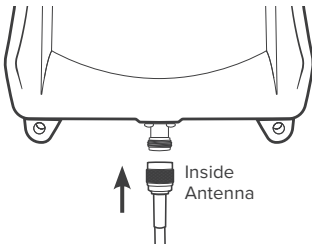

2

Connect the supplied **Coax Cable** to end of booster labeled **Inside Antenna**.



Warning: Do Not connect power supply to booster before connecting both outside and indoor antennas

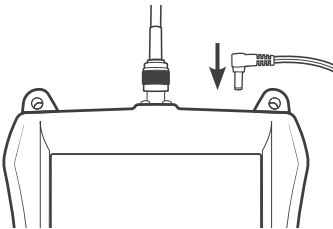

3

Power up the Booster by connecting it to a power source.

To protect Booster from power surges, connect to a power strip.

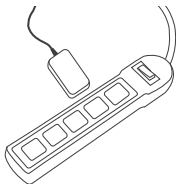

Step 7: Compare Results

Using the field test mode described in step 3, measure the new signal strength and write it down here _____.

Compare this number with the original reading you took in the same part of the house. If the number is higher (closer to zero) than the original reading without booster, your booster is working. If it is not, look at the lights on the booster and the section at the end of this manual “Test System: Lights”.

Users on iOS 11 and above will need to use an alternative method using the bar indicator on your cell phone and/or placing calls in different locations.

Did you know a signal increase in just 3dB is 2 times the power and signal amplification!

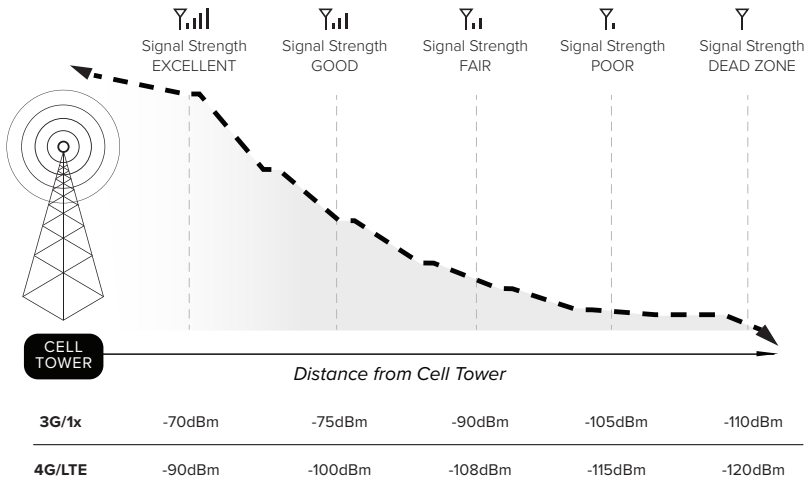

DECIBEL GAIN

POWER INCREASE

3dB	2 times the power and signal amplification
6dB	4 times the power and signal amplification
10dB	10 times the power and signal amplification
12dB	16 times the power and signal amplification
20dB	100 times the power and signal amplification

Step 8: Permanently Mount The Outside Antenna

Option **A**: Outside Roof/Pole Mount (Best Option)

Mount, or use an existing pipe in an optimal signal location. Watch out for power lines.

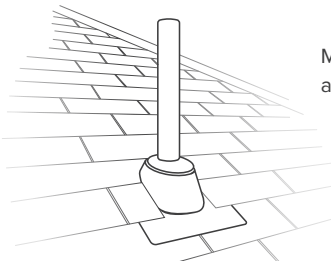
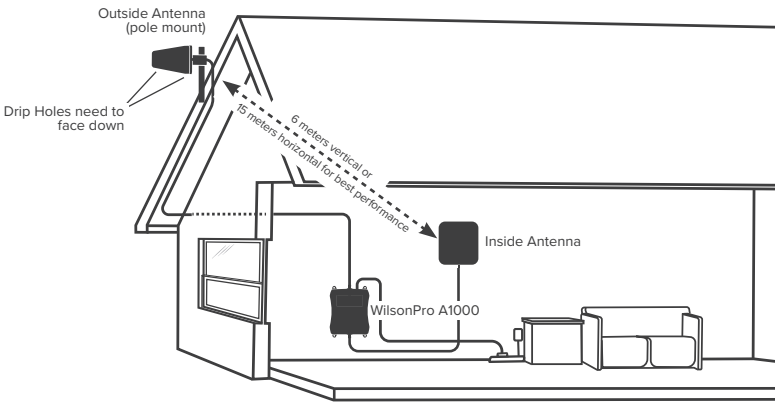

Mounting on existing roof exhaust pipe would be a good time-saver option.

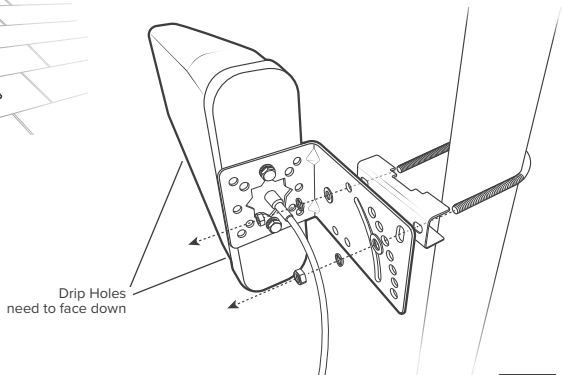

(STEP 8 cont.)

Option **B**: Mounting on side of roof (Good Option)

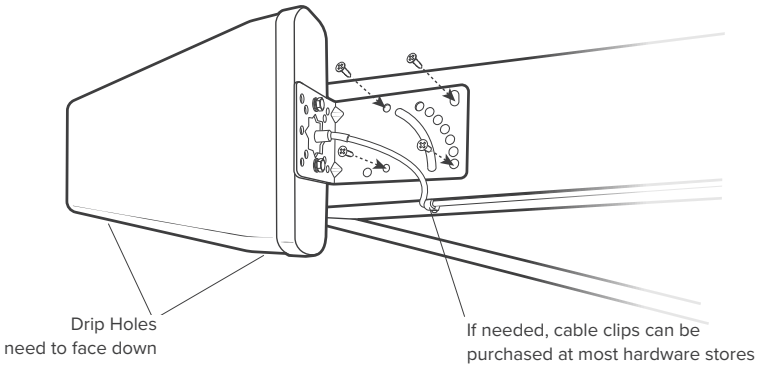
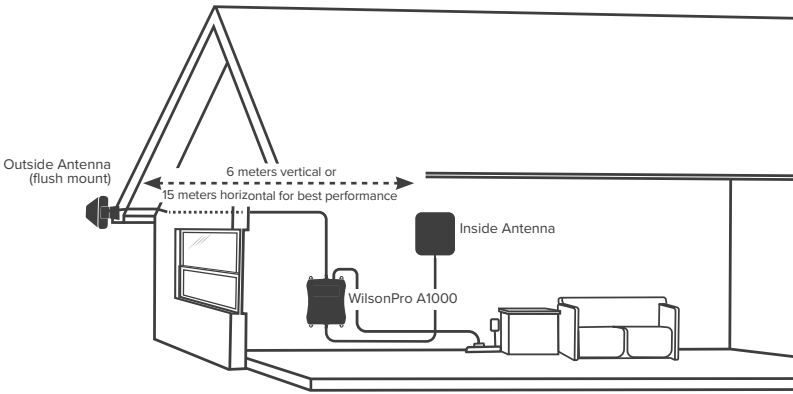

Step 9: Permanently Mount The Inside Antenna

Position bracket on wall and use a pencil to mark the holes. Drill holes using 3/16 inch bit. Use anchors, washers and screws to attach Wall Bracket.

Slip Inside Antenna onto the Wall Mount Bracket to secure.

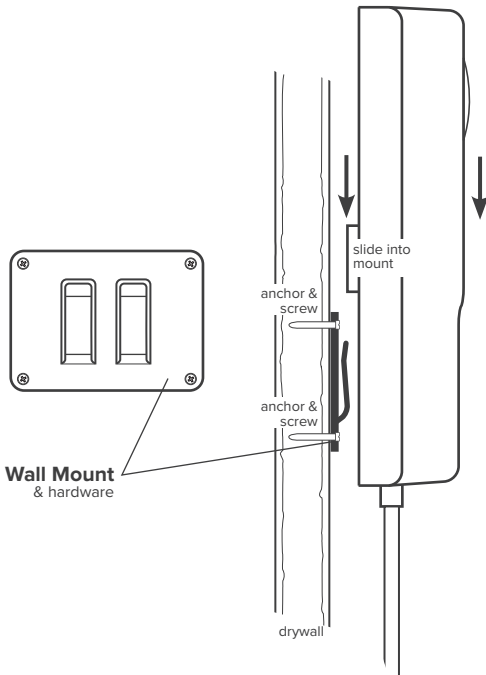

Step 10: Route & Secure The Cable

Secure cable on outside home/office. Some homes have eaves you can tuck the cable between the soffit and the exterior wall. If needed, cable clips/ties can be purchased at most hardware stores.

Look out for entry points such as spaces between brick and roof, aircon ducts, existing conduits or cable lines or air vents.

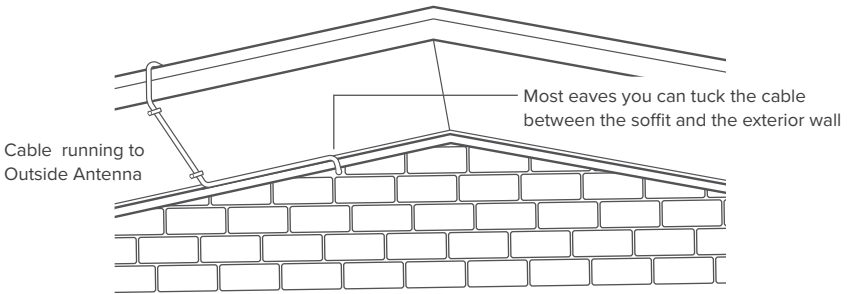

Create cable loops to protect from lightning and prevent water leaks

Lightning likes to travel in straight lines through a medium. A loop before the lightning surge protector creates a deviation from the lightning's desired path thus protecting the system. Also looping the cable before the entry point into home will allow water to drip down from the loop and not cause water damage in the home.

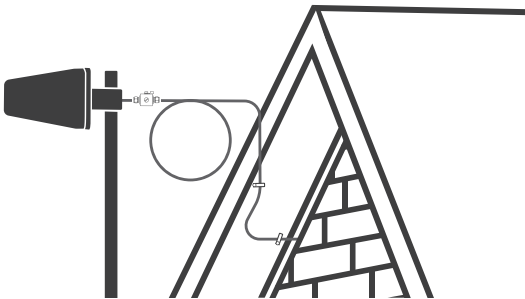

Test System: Lights



Each light corresponds to a frequency band.



IMPORTANT: To get an accurate reading of the lights, unplug and re-plug the power supply from the Booster.

No Lights

Booster does not have power. Un-plug and securely re-plug in power supply.

Fix Any Red Light Problems (red indicates oscillation)

• If you are happy with coverage, red lights don't have to be resolved.

- **Solid Red** = Band has shut off
- **Blinking Green/Red** = Band has reduced gain

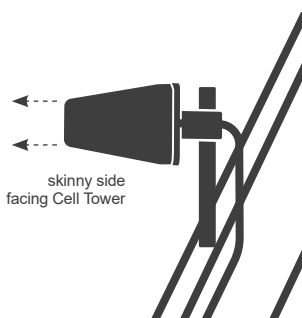

- 1 Verify Outside Antenna faces away from the Inside Antenna. Un-plug and re-plug in power supply.
- 2 Verify the Inside Antenna is at least 45cm from the Booster and pointed away from the Booster. Un-plug and re-plug in power supply.
- 3 Tighten all cable connections. You may want to undo and redo the connection completely. Un-plug and re-plug in power supply.
- 4 BEST: Increase the distance (horizontally or vertically) between the Outside and Inside Antenna. Add cable if needed. Un-plug and re-plug in power supply.

(TEST SYSTEM: LIGHTS cont.)

Fix Any Orange Light Problems (orange indicates a cell tower is close by)

If you are happy with coverage, orange lights don't have to be resolved

- **Solid Orange** = Band has shut off
- **Blinking Green/Orange** = Band has reduced gain.

- 1 If the light is **solid orange**, the Outside Antenna must be adjusted (see below). Wait 10 seconds between adjustments for the lights to reset.
 - For Roof/Pole Mount Option = Rotate the Outside Antenna away from the strongest cellular signal in small increments (45°) until the light turns **green**. Un-plug and re-plug power supply.
 - For All Other Mount Options = Change mount location. For example, if the Outside Antenna is a window mount, move the Outside Antenna to a wall outside the building to see if the lights turn **green**. Un-plug and re-plug power supply.
- 2 If the light is **blinking green/orange**, re-locate the Outside Antenna. Un-plug and re-plug power supply.

All Green Lights? = Band is set up optimally. Verify you have good coverage.

If you have green lights, but poor coverage:

- Rotate the Outside Antenna in small increments (roof/pole mount only). Un-plug and re-plug power supply.
- Move the Outside Antenna to a different location. Un-plug and re-plug power supply.
- Change the method of mounting the Outside Antenna. Un-plug and re-plug power supply.

WilsonPro A1000 Specifications

Product	WilsonPro A1000-3G/4G		
Model Number	520002		
Connectors	N-Female		
Antenna Impedance	50 Ohms		
Frequency MHz	Band 1 (2100)	Band 3 (1800)	Band 8 (900)
Power output for single cell phone	B1	B3	B8
	UPLINK 30dB DOWNLINK 25dB	30dB 25dB	30dB 25dB
Passband Gain (nominal)	B1	B3	B8
	74	74	66
Noise Figure (typical downlink/uplink)	5 dB nominal		
Power Requirements	5.5V DC, 1.5A		

Lightning Surge Protector

↑ To Outside Antenna

← Ground Wire (not included)

↓ To Signal Booster

RECOMMENDED: INSTALLING THE LIGHTNING SURGE PROTECTOR

INSTALL THE LIGHTNING SURGE PROTECTOR (LSP) CLOSE TO THE SIGNAL BOOSTER. ATTACH THE CABLE FROM THE OUTSIDE ANTENNA TO THE SURGE PROTECTOR. **ENSURE THE LSP IS PROPERLY GROUNDED.**

Safety Guidelines

Warnings

To uphold compliance with network protection standards, all active cellular devices must maintain at least 2 meters of separation distance from Inside Panel and Dome antennas and at least 1.2 meters of separation distance from desktop Antenna.

Use only the power supply provided in this package. Use of a non-WilsonPro product may damage your equipment.

The Signal Booster unit is designed for use in an indoor, temperature-controlled environment (less than 38 degrees Celsius). It is not intended for use in attics or similar locations subject to temperatures in excess of that range.

RF Safety Warning: Any antenna used with this device must be located at least 20 centimeters from all persons.

This is a CONSUMER device.

The WilsonPro A1000 is an Approved and Registered Device. Most wireless providers consent to the use of signal boosters. Some providers may not consent to the use of this device on their network. If you are unsure, contact your provider.

You **MUST** cease operating this device immediately if requested by a licensed wireless service provider.

Antenna Kit Options

The following accessories are to be used with the WilsonPro **A1000 Booster**.

INSIDE ANTENNA EXPANSION KITS

BT512952 – 1 Extra PANEL antenna expansion kit:

1 x Wall mount panel antenna

1 x 2-way splitter

1 x 15m and 1x 0.5m cable lengths ended with connectors

BT512969– 1 Extra DOME antenna expansion kit:

1 x Ceiling mount dome antenna

1 x 2-way splitter;

1 x 15m and 1x 0.5m cable lengths ended with connectors

BT512976 – 2 Extra PANEL antenna expansion kit:

2 x Wall mount panel antenna

1 x 3-way splitter

2 x 15m and 1 x 0.5m cable lengths ended with connectors

BT512969– 2 Extra DOME antenna expansion kit:

2 x Ceiling mount dome antenna

1 x 3-way splitter

2 x 15m and 1x 0.5m cable lengths ended with connectors

BT512976 – 3 Extra PANEL antenna expansion kit:

3 x Wall mount panel antenna

1 x 4-way splitter

3 x 15m and 1 x 0.5m cable lengths ended with connectors

BT512969– 3 Extra DOME antenna expansion kit:

3 x Ceiling mount dome antenna

1 x 4-way splitter

3 x 15m and 1x 0.5m cable lengths ended with connectors

Warranty

1 YEAR WARRANTY

WilsonPro Signal Boosters are warranted for one (1) year against defects in workmanship and/or materials. Warranty cases may be resolved by returning the product directly to Bolton Technical with a dated proof of purchase.

Signal Boosters should be returned with a dated proof of purchase and a Returned Material Authorization (RMA) number supplied by Bolton Technical. Bolton Technical shall at its option either repair or replace the product.

This warranty does not apply to any Signal Boosters determined by Bolton Technical to have been subjected to misuse, abuse, neglect, or mishandling that alters or damages physical or electronic properties.

Replacement products may include refurbished WilsonPro products that have been recertified to conform with product specifications.

RMA numbers may be obtained by contacting Customer Support

DISCLAIMER: The information provided by WilsonPro is believed to be complete and accurate. However, no responsibility is assumed by WilsonPro for any business or personal losses arising from its use, or for any infringements of patents or other rights of third parties that may result from its use.



WILSONPRO™



Represented by Bolton Technical: Sole Distributors in Africa

Copyright © 2021 WilsonPro. All rights reserved.
WilsonPro products covered by U.S. patent(s) and pending application(s).
For patents go to: WilsonPro.com/us/patents

NOT AFFILIATED WITH WILSON ANTENNA